

# ROTO 40.30 MCSS

Provisional Information

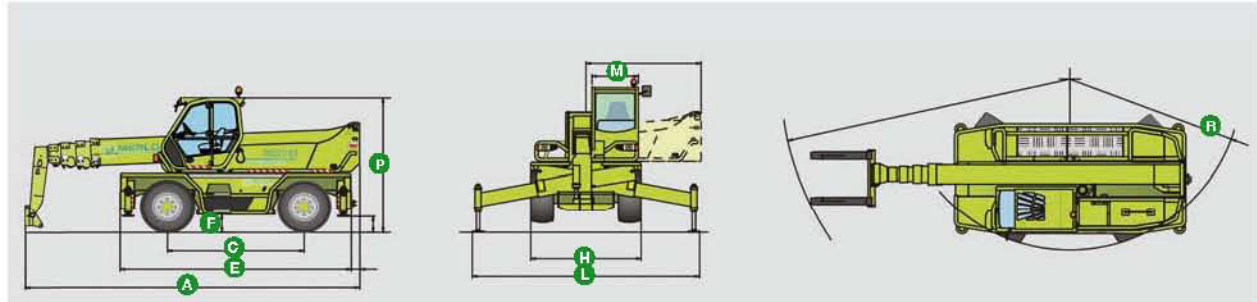

*BUILDING WITH CONFIDENCE*



Conceived to deliver high performance and profitability, the new **Roto 40.30 MCSS** has the high technology to be a winning solution for every task. Capable of lifting to almost **30 metres** it provides a new standard of on-site versatility.

<b>A</b> (mm)	7560
<b>C</b> (mm)	3200
<b>E</b> (mm)	5540
<b>F</b> (mm)	350
<b>H</b> (mm)	2490
<b>L</b> (mm)	5275
<b>M</b> (mm)	995
<b>P</b> (mm)	3150
<b>R</b> (mm)	4800

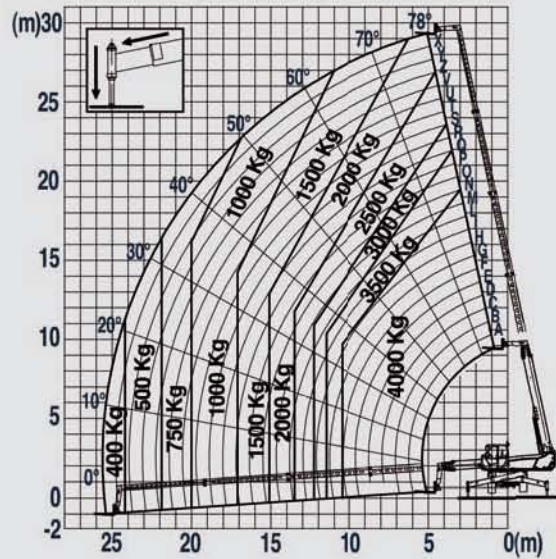

Continuous 360 degree turret rotation is made possible with an exclusive **Merlo rotating coupling**, state of the art in terms of **practicality, safety and comfort**. The **Load-Sensing** hydraulic system, **hydropneumatic suspension and levelling**, and **independent stabilisers**, ensure the ability to configure the machine for maximum safety and performance, whatever the stabiliser setup.

For the best possible load visibility, the **cab can be tilted** through 10 degrees.

Operating weight (kg)	19,800
Max lift capacity (kg)	4000
Max lift height (m)	29.2
Max forward reach (m)	25.5
Lift height with max capacity (m)	19
Forward reach with max capacity (m)	10
Capacity at max lift height (kg)	2000
Capacity at max forward reach (kg)	350
Power - Euro r Turbo-Intercooler (kW/HP)	129/176
Turret rotation (degrees)	Continuous
Merlin digital control system	Standard
Tilting cab module	Standard
Hydropneumatic suspension	Standard
Load-sensing hydraulic system	Standard



MERLO S.P.A.

Via Nazionale, 9 - 12010 S. Defendente di Cervasca - Cuneo - Italia

Tel. +39 0171 614111 - Fax +39 0171 684101

[www.merlo.com](http://www.merlo.com) - [info@merlo.com](mailto:info@merlo.com)